

Operating Instructions

ACCULAB ATILON

Electronic Analytical and Precision Balances

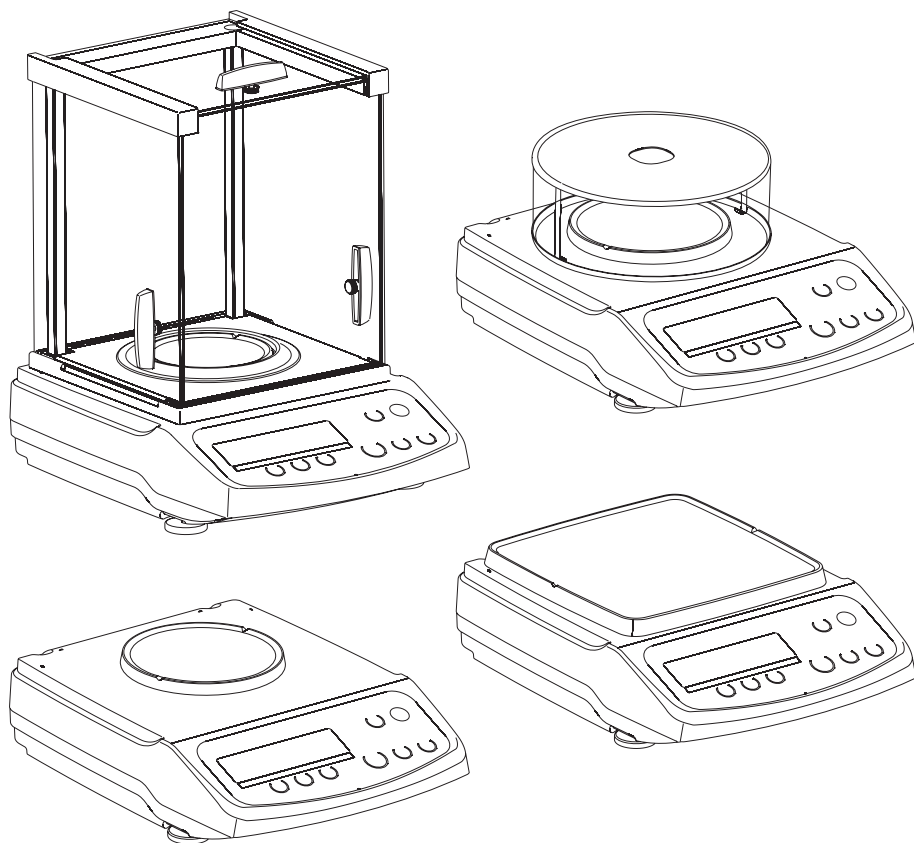

Contents

- 3 **Warnings and Safety Precautions**
- 4 **Getting Started**
- 5 **Installation**
- 10 **Operation**
 - 10 Display and Operating Elements
 - 11 Basic Weighing Function
 - 13 Calibration/Adjustment
- 16 **Configuration (Operating Menu)**
 - 16 Functions of the Keys during Configuration
 - 17 Menu Navigation; Example: Setting the Language
 - 18 Parameter Settings: Menu
 - 19 Parameter Settings: Overview
 - 23 Input: ID Number, Date and Time
- 25 **Application Programs**
 - 26 Counting
 - 28 Weighing in Percent
 - 30 Calculation
 - 32 Animal Weighing/Averaging
 - 34 Net-total Formulation
 - 36 Totalizing
 - 38 Density Determination
 - 40 Mass Unit Conversion
- 43 **ISO/GLP-compliant Printout/Record**
- 45 **Data Interface**
- 46 **Troubleshooting Guide**
- 47 **Care and Maintenance**
- 48 **Recycling**
- 49 **Overview**
 - 49 Specifications
 - 52 Accessories
 - 53 **CE-Marking**

Warnings and Safety Precautions

Safety

- To prevent damage to the equipment, please read these operating instructions carefully before using the balance.
- △ Do not use this equipment in hazardous areas.
- △ The balance may be opened only by trained service technicians.
- △ Disconnect the balance from power before connecting or disconnecting peripheral devices.
- △ If you operate the balance under ambient conditions subject to higher safety standards, you must comply with the applicable installation regulations.
- △ Exposure to excessive electromagnetic interference can cause the readout value to change. Once the disturbance has ceased, the instrument can be used again in accordance with its intended purpose.
Make sure that no liquid enters the equipment housing; use only a slightly moistened cloth to clean the balance.

Installation

- △ Make sure the voltage rating printed on the power supply is identical to your local line voltage.
- Proceed with extreme caution when using pre-wired RS-232 connecting cables, as the pin assignments may not be compatible with Acculab equipment. Before connecting the cable, check all pin assignments against the cabling diagrams and disconnect any lines that are assigned differently.
- △ If there is visible damage to the equipment or power cord, disconnect the equipment from power and lock it in a secure place to ensure that it cannot be used for the time being.

- Connect only Acculab accessories, as these are optimally designed for use with your Atilon balance. The operator shall be solely responsible for installation and testing of any modifications to Acculab equipment, including connection of cables or equipment not supplied by Acculab. On request, Acculab will be happy to provide information on operating specifications (in accordance with the Standards for defined immunity to interference).
- Do not open the balance housing. If the seal is broken, this will void all claims under the manufacturer's warranty.
- If you have any problems with your balance, contact your local customer service center.

Symbols

The following symbols are used in these instructions:

- indicates required steps
- indicates steps required only under certain conditions
- > describes what happens after you have performed a particular step
- indicates an item in a list
- △ indicates a hazard

Getting Started

Storage and Shipping Conditions

- Do not expose the balance to extreme temperatures, moisture, shocks, blows or vibration.

Unpacking the Equipment

- After unpacking the equipment, please check it immediately for any external damage.
- If you detect any damage, proceed as directed in the chapter entitled “Care and Maintenance,” under “Safety Inspection.”
- Save the box and all parts of the packaging for any future transport. Disconnect all cables before packing the balance for shipping.

Equipment Supplied

- Balance
- Weighing pan
- Pan support (only for models with a round weighing pan)
- AC adapter

Additional equipment supplied with models

ATL-224, -124:

- Sliding-door draft shield
- Drip/breeze ring
- Draft shield base plate

Additional equipment supplied with models

ATL-623, -423, -153:

- Round glass draft shield with cover

Installation

Choose a location that is not subject to the following negative influences:

- Heat (heater or direct sunlight)
- Drafts from open windows and doors
- Excessive vibration during weighing
- Excessive moisture

Conditioning the Balance

Moisture in the air can condense on cold surfaces whenever the equipment is moved to a substantially warmer place. To avoid the effects of condensation, allow the balance to sit for 2 hours, at room temperature, before plugging into AC power.

Seal on Balances Verified for Use in Legal Metrology in the EU*:

EU legislation requires that a control seal be affixed to verified balances. The control seal consists of a sticker. If the seal is broken, the verification becomes null and void and the balance must be re-verified.

* Including the Signatories of the Agreement on the European Economic Area

Installation

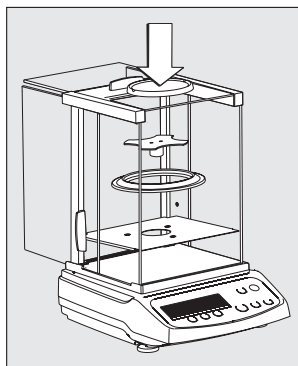

Setting Up the Balance

Instruments with sliding-door draft shield:

- Place components inside the chamber in the following order:
 - Draft shield base plate
 - Drip/breeze ring
 - Pan support
 - Weighing pan

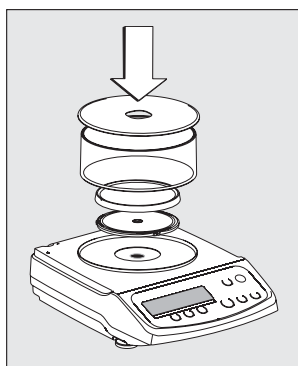

Instruments with a round glass draft ring:

- Position the components listed below in the order given:
 - Place the lower lid on the balance with the raised edge facing upwards
 - Pan support
 - Weighing pan
 - Glass draft ring
 - Place the upper lid on the draft shield ring with the raised edge facing downwards

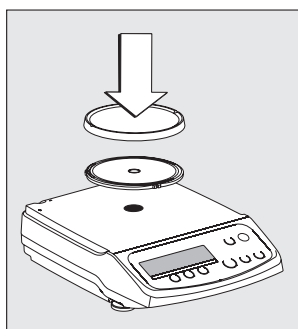

Instruments with a round weighing pan

- Position the components listed below in the order given:
 - Pan support
 - Weighing pan

Instruments with a rectangular weighing pan:

- Place the weighing pan on the balance

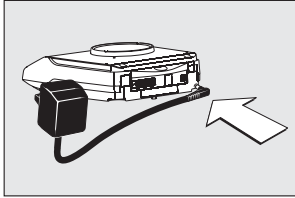

Connecting the Balance to AC Power/Safety Precautions

Use only original Acculab AC adapters. For use within

- Europe: part no. 6971412
- U.S./Canada: part no. 6971413
- Connect the angle plug to the balance
- Connect the AC adapter to the wall outlet (mains)

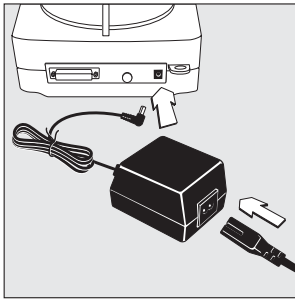

AC Adapter with Country-specific Power Cord

Some models come with separate country-specific power cords for the AC adapter.

- Connect the angle plug to the balance
- Select the power cord for your area and connect it to the AC adapter
- Plug the power cord into the wall outlet (mains)

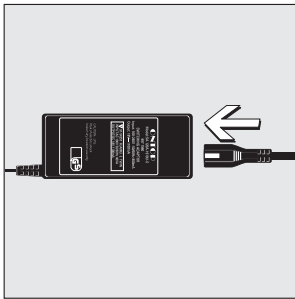

Use an original Acculab AC adapter with a wide input voltage range

- (100 to 240 V~), order no. 6971966, and replaceable power cord:

6900900 (Europe)	6900905 (AUS)
6900901 (US/CDN)	6900902 (ZA)
6971945 (UK)	6971977 (Argentina)
6971973 (India)	6971978 (China)
6971980 (Denmark)	6971975 (Israel)
6971776 (Italy)	

Safety Precautions

Plug-in AC Adapter 6971412/6971413:

The AC adapter rated to Class 2 can be plugged into any wall outlet without additional safety precautions.

Benchtop AC Adapter 6971966:

The AC adapter rated to Class 1 can be plugged into any wall outlet without additional safety precautions.

The ground terminal is connected to the balance housing, which can be additionally grounded for operation. The data interface is also electrically connected to the balance housing (ground).

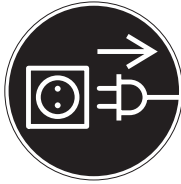

Connecting Electronic Peripheral Devices

- Make sure to unplug the balance from AC power before you connect or disconnect a peripheral device (printer or computer) to or from the interface port.

Warmup Time

To ensure accurate results, the balance must warm up before operation as follows:

- Models ATL-153 and ATL-822: 2 hours
- All other models: 30 minutes

Only after this time will the instrument have reached the required operating temperature.

Using Verified Balances in Legal Metrology in the EU*:

- Make sure to allow the equipment to warm up for at least 24 hours after initial connection to AC power or after a relatively long power outage.

Operation Outside the Temperature Range

- △ Operating the balance beyond the temperature range of $+10 \dots +30^{\circ}\text{C}$ ($50 \dots 86^{\circ}\text{F}$). Differences from the specifications listed in the chapter on “Specifications” are possible.

* Including the Signatories of the Agreement on the European Economic Area

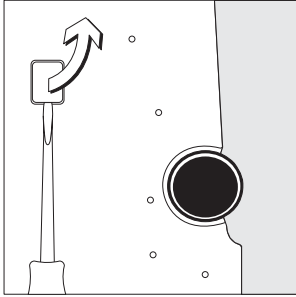

Below-Balance Weighing

A port for a below-balance weighing hanger is located on the bottom of the balance.

- Below-balance weighing is not permitted in legal metrology.
- Open cover plate on the bottom of the balance.
Important: set the balance on its side to access the cover plate. DO NOT turn the balance upside-down.

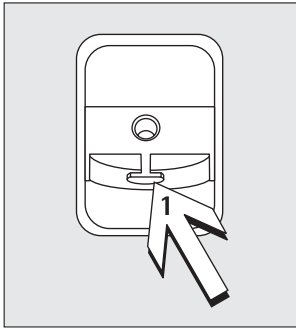

- Using the built-in hook **1**: Attach the sample (e.g., using a suspension wire) to the hanger.
- Install a shield for protection against drafts if necessary.

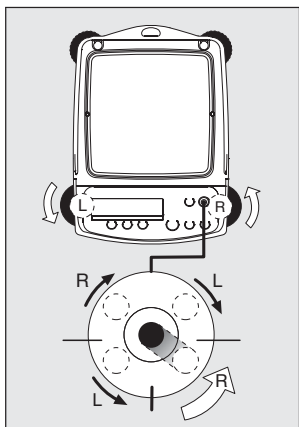

Leveling the Balance

Purpose:

- To compensate for unevenness at the place of installation

Always level the balance again any time after it has been moved to a different location. Only the 2 front feet are adjusted to level the balance.

- Retract the two rear feet (only on models with a rectangular weighing pan).
- Turn the 2 front feet as shown in the diagram until the air bubble is centered within the circle of the level indicator.
- > In most cases this will require several adjustment steps.
- On models with a rectangular weighing pan: Lower the 2 rear feet until they touch the surface on which the balance rests.

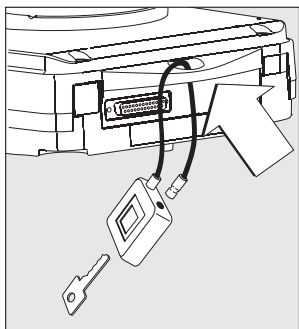

Anti-theft Locking Device

- To secure the balance at the place of installation, fasten a chain or a lock to the lug located on the rear panel of the balance.
- Anti-theft locking device (chain and lock): order number LC-1

Basic Weighing Function

Features

- Taring the balance
- Printing weights

Preparation

- Switch on the balance:
Press (ON/OFF)
- Tare the balance, if necessary:
Press (TARE)
- If necessary, change the configuration settings:
See the chapter entitled "Configuration"
- If desired, load the factory settings:
See the chapter entitled "Configuration"

Additional Functions

- Switching off the balance:
Press (ON/OFF)
- Balance in standby mode:
the current time is displayed

Using Verified Balances as Legal Measuring Instruments in the EU*

The type-approval certificate for verification applies only to non-automatic weighing instruments. For automatic operation with or without auxiliary measuring devices, you must comply with the regulations applicable to the place of installation.

- Before using the balance as a legal measuring instrument, calibrate and adjust it at the place of use using the built-in motorized calibration weight; for details, see "Calibration/Adjustment" in this chapter.
- The temperature range (°C) indicated on the verification label must not be exceeded during operation.

* Including the Signatories of the Agreement on the European Economic Area

Example

Simple Weighing

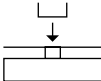
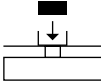
Step	Key (or instruction)	Display/Printout
Balance in standby mode		10:32:30
1. Switch on the balance Self-test is performed, followed by automatic initial tare function.	(ON/OFF)	0.0 g
2. Place container on weighing pan (in this example: 11,5 g).		+ 11.5 g
3. Tare the balance	(TARE)	0.0 g
4. Place sample in container (in this example: 132 g).		+ 132.0 g
5. Print weight	(PRINT)	N + 132.0 g

Calibration and Adjustment

Purpose

Calibration is the determination of any difference between the measured value displayed and the true weight (mass) of a sample. Adjustment is the correction of this difference, or its reduction to an allowable level within maximum permissible error limits.

Using Verified Balances as Legal Measuring Instruments in the EU*: Before using your balance as a legal measuring instrument, internal calibration must be performed at the place of installation.

Features

Calibration/adjustment can be performed only when:

- there is no load on the balance
- the balance is tared
- the internal signal is stable
- for external calibration, the value displayed for the calibration weight on the balance does not differ from the nominal weight value by more than 2%

If these conditions are not met, an error message is displayed "ERR 02".

You can use any of the following weight units in calibration/adjustment:

`CAL.EINH. - GRAMM, KILOGR. or POUND`
(not for verified models)

To block calibration/adjustment:

- Select `CAL.-ADJ.-BLOCKED` in the menu
- Close the menu access switch on the back of the balance

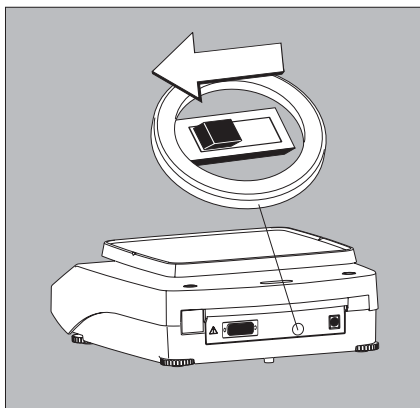

External Calibration in Verified Balances

When the balance is used in legal metrology, external calibration is blocked as follows:

- The setting of the menu access switch is locked (see "To block calibration/adjustment")
- The cap over the menu access switch is sealed

For details on generating an ISO/GLP-compliant printout of calibration/adjustment results, see page 43.

Following calibration/adjustment, the application program is cleared.

Internal Calibration/Adjustment

In the operating menu, select `CAL.-ADJ.-CAL.INT.` before beginning.

The built-in motorized calibration weight is applied and removed automatically for internal calibration.

- Select calibration/adjustment: Press (CAL)
- > The built-in weight is applied automatically
- > The balance is adjusted
- > The built-in calibration weight is removed.

* Including the Signatories of the Agreement on the European Economic Area

Internal Calibration/Adjustment (Only on ATL...-I und ATL...-V models)

Set the following parameters:

SETUP-WPAGE-CAL.JUST.-CAL.INT. (menu code 1.1.9.4)

The built-in motorized calibration weight is applied and removed automatically for internal calibration.

Step	Key (or instruction)	Display
1. Tare the balance	(TARE)	0.0 g
2. Start calibration	(CAL)	CAL.INT.
		CAL.RUN.
3. Calibration/adjustment executed		CAL.END
4. The built-in weight is removed		0.0 g

External Calibration

Parameters (changes in factory settings):

SETUP-WAAGE-CALJUST.-CALEXT. (menu code 1.1.9.1)

The required calibration weight is configured at the factory (see "Specifications")

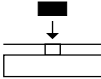
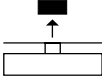
Step	Key (or instruction)	Display
1. Tare the balance	(TARE)	0.0 g
2. Start calibration. Once you store the zero point the required calibration weight is prompted (flashing display)	(CAL)	CALEXT. - 5000.0 g
3. Apply the prompted calibration weight (in this example: 5000 g) Weight too light: a minus sign "-" is shown Weight too heavy: a plus sign "+" is shown The display stops flashing as soon as the weight value is within the defined limit.		5000.0 g
4. Calibration/adjustment executed; then the calibration weight is displayed		CALEND + 5000.0 g
5. Remove the calibration weight		0.0 g

Configuration (Operating Menu)

You can configure the balance; i.e., adapt it to individual requirements.

Functions of the Keys during Configuration

Symbol	Key	Function
V	(MENU)* Press and hold	Scroll through menu items
>	(ENTER)	One menu level lower
↵	(ENTER)	Confirm menu item
	(CLEAR) Press and hold	Save settings and exit menu from any position
<<	(CLEAR)	Save settings and exit menu
<	(CLEAR)	One menu level higher
[••••]		Indicates menu level

* On some models, the keypad overlay shows the German word "MENUE" for MENU.

Menu Navigation

Example: Setting the Language

Step	Key (or instruction)	Display
1. Open the menu: In weighing mode: first menu item is shown	(MENU)* (hold)	APPLIC.
2. Scroll upward within the menu level; after the last menu code, the first code is displayed again	Repeatedly: (MENU)*	INPUT ... LANGUAG.
3. Select menu level	Repeatedly: (ENTER) (scrolls to the right)	ENGLISH 0
4. Change setting: Scroll until the desired setting is shown	(MENU)*	ESPAÑOL
5. Confirm the menu code; "0" indicates the active setting	(ENTER)	ESPAÑOL 0
6. Return to the next higher menu level (from the second level)	(CLEAR)	LENGUA
○ Set other menu items as desired	(MENU)*, (ENTER)	
7. Save settings and exit menu	Repeatedly: (CLEAR)	
or		
○ Exit menu without saving changes	(ON/OFF)	
> Restart your application		0.0 g

* On some models, the keypad overlay shows the German word "MENUE" for MENU.

Parameter Settings: Menu

Level 1 [●]	Level 2 [●●]	Level 3 [●●●]	Menu code	
SETUP	BAL.SCAL. Balance parameters	AMBIENT Ambient conditions	1.1.1.	
		APP.FIL. Application filter	1.1.2.	
		STAB.RNG. Stability range	1.1.3.	
		TARING. Taring ¹⁾	1.1.5.	
		AUTOZER. Auto zero	1.1.6.	
		WT.UNIT Basic weight unit	1.1.7.	
		DISP.LY. Display accuracy ¹⁾	1.1.8.	
		CAL.ADJ. Function of the (CAL) key	1.1.9.	
		CAL.UNIT. Weight unit for calibratio ¹⁾	1.1.11.	
		INTERF. Interface	BAUD. Baud rate	1.5.1.
	PARITY Parity		1.5.2.	
	STOPBIT Number of stop bits		1.5.3.	
	HANDBSHK. Handshake mode		1.5.4.	
	DATABIT Number of data bits		1.5.5.	
	BT.REC. Output: SBI (ASCII) or printout		1.5.6.	
	PRINT (manual/automatic)		1.6.1.	
	STOPAUT. Stop automatic printing		1.6.2.	
	PRNT.OUT Settings for print function	TAR./PRNT. Tare balance after ind. print	1.6.4.	
		PRNT.INIT. Printout of appl. parameters	1.6.5.	
		FORMAT Line format for printout	1.6.6.	
		GLP ISO/GLP-compliant printout	1.6.7.	
		TIME 12h/24h	1.6.8.	
		DATE-Format	1.6.9.	
MENU		1.8.1.		
SIGNAL Acoustic signal (beep)		1.8.2.		
EXTRAS Additional functions	KEYS Keypad	1.8.3.		
	EXT.KEYS. Funktion external Keypad	1.8.4.		
	ON.MODE Power-on mode	1.8.5.		
	BACKLIT Display backlighting	1.8.6.		
	MENU Factory settings	1.9.1.		
	RESET			
	APPLIC. Application programs	WEIGH		2.1.
		UNIT TOGGLE wrt. unit	DISP.DIG. Display accuracy ¹⁾	2.2.2.
COUNT		COUNTING. Resolut. Resolution	2.3.1.	
		REF.UPDT. Autom. ref. sample updating	2.3.2.	
PERCENT Weighing in percent		DEC.PLCS Decimal places	2.4.1.	
NET-TOT Net-total formulation		COMP.PRT. Printout of components	2.5.1.	
TOTAL Totalizing		COMP.PRT. Printout of components	2.6.1.	
ANIMALW. Animal weighing		ACTIVITY. Animal activity	2.7.1.	
		START	2.7.2.	
CALC. Calculation		METHOD (operator)	2.8.1.	
		DEC.PLCS Decimal places	2.8.2.	
DENSITY Density determination		DEC.PLCS Decimal places	2.9.1.	
INPUT Input		INDNO., DATE, TIME	Input: ID no., date, time	3.1./2./3.
INFO Information	VERSION, SER.NO., MODEL	Display software ver., serial no., model	4.1./2./3.	
LANGUAG.	ENGLISH (factory setting)		5.1.	
	DEUTSCH German		5.2.	
	FRANC. French		5.3.	
	ITAL. Italian		5.4.	
	ESPAÑOL Spanish		5.5.	
	РУССКИЙ Russian		5.6.	
	POLSKI Polish		5.7.	
	CODES Menu shows codes (not texts)		5.8.	

¹⁾ Setting cannot be changed on verified balances

Parameter Settings: Overview

○ = Factory setting ✓ = User-defined setting

Level 1 [•]	Level 2 [••]	Level 3 [•••]	Level 4 [••••]	Menu code
SETUP	BAL.SCAL. Balance parameters	AMBIENT Ambient conditions (Filter adaptation)	✓ V.STABLE Very stable	1.1.1.1
			○ STABLE	1.1.1.2
			UNSTABL	1.1.1.3
			V.UNSTBL. Very unstable	1.1.1.4
		APP.FILT. Application filter	○ FINAL.RD. Final readout mode	1.1.2.1
			FILLING Filling mode	1.1.2.2
		STAB.RNG. Stability range	1/4-DIG. (digit)	1.1.3.1
			1/2-DIG.	1.1.3.2
			1-DIGIT	1.1.3.3
			○ 2-DIGIT	1.1.3.4
			4-DIGIT	1.1.3.5
			8-DIGIT ¹⁾	1.1.3.6
		TARING ¹⁾ Taring	W/O STB W/o stability	1.1.5.1
			○ W/ STAB After stability	1.1.5.2
		AUTOZER. Auto zero	OFF	1.1.6.1
○ ON	1.1.6.2			
WT.UNIT Basic weight unit	For list of units, see "Toggling between Weight Units"		1.1.7.1	
			1.1.7.23	
DISP.DIG. ¹⁾ Display accuracy	○ ALL	1.1.8.1		
	MINUS 1	1.1.8.2		
CAL.ADJ. Function of the (CAL) key	○ CAL.EXT. External cal./adj. ¹⁾	1.1.9.1		
	CAL.INT. Internal cal./adj. ²⁾	1.1.9.2		
	BLOCKED (CAL) key blocked	1.1.3.3		
CAL.UNIT. Unit ¹⁾ for calibration weight	○ GRAMS	1.1.11.1		
	KILGR. Kilograms	1.1.11.2		
	POUNDS ¹⁾	1.1.11.3		

¹⁾ Setting cannot be changed on verified balances

²⁾ Only on ATL-...-I, ATL-...-V models

Level 1 [•]	Level 2 [••]	Level 3 [•••]	Level 4 [••••]	Menu code
SETUP	INTERF. Interface	BAUDrate	600	1.5.1.3
			o 1200	1.5.1.4
2400			1.5.1.5	
4800			1.5.1.6	
9600			1.5.1.7	
19200			1.5.1.8	
PARITY			o 000	1.5.2.3
			EVEN	1.5.2.4
		NONE	1.5.2.5	
STOPBIT No. of stop bits		o 1STOP	1.5.3.1	
		2STOP	1.5.3.2	
HANDSHK. Handshake mode	o SOFTW.ore	1.5.4.1		
	o HARDW.ore	1.5.4.2		
	NONE	1.5.4.3		
DATABIT No. of data bits	o 7BITS	1.5.5.1		
	8BITS	1.5.5.2		
DAT.REC. Communication mode	o SBI (ASCII) ¹⁾	1.5.6.1		
	o PRINTER (GLP-printout)	1.5.6.2		
PRINT.OUT Printing fct.	PRINT (manual/ automatic)	o MAN. W/O W/o stability	1.6.1.1	
		o MAN.WITH W/ stability	1.6.1.2	
		o AUT. W/O Autom. w/o stability	1.6.1.3	
		o AUT.WITH. Autom. w/ stability	1.6.1.4	
	STOPAUT. Stop automatic printing	o OFF Not possible	1.6.2.1	
		o ON Use print key (PRINT)	1.6.2.2	
	AUT.CYCL. Time-dependent automautomatic printing	o EACHVAL (1 display update)	1.6.3.1	
	TAR./PRT. Tare the balance after individual printout	o OFF	1.6.4.1	
		o ON	1.6.4.2	

¹⁾ Note concerning verified balances as legal measuring instruments in the EU*:
In the setting "SBI", the non-verified display digit is not automatically identified.
Please take the corresponding measures or adjust the settings on the peripheral device.

* Including the signatories of the Agreement on the European Economic Area.

Level 1 [•]	Level 2 [••]	Level 3 [•••]	Level 4 [••••]	Menu code
SETUP	PRNT.OUT Printing	PRT.INIT. Printing application parameters	OFF	1. 6. 5. 1
			o ALL All parameters	1. 6. 5. 2
			MAINPAR. Main parameters	1. 6. 5. 2
		FORMAT Line format for printout	16 CHAR. 16 characters (w/o ID)	1. 6. 6. 1
			o 22 CHAR. 22 characters (w/ID)	1. 6. 6. 2
			2 CHAR. 2 characters (w/ID) (Date/Time and weight value)	1. 6. 6. 3
		GLP Printout as ISO/GLP-compliant	o OFF	1. 6. 7. 1
			CAL.-ADJ. Only for calib./adj.	1. 6. 7. 2
			ALWAYS All printouts	1. 6. 7. 3
		TIME	24H 24-hour format	1. 6. 8. 1
	12H 12-hour format "AM/PM"		1. 6. 8. 2	
	DATE	DD.MM.YY Day/month/year	1. 6. 9. 1	
		MM.DD.YY Month/day/year	1. 6. 9. 2	
	EXTRAS Additional functions	MENU*	o CANEDIT Can change settings	1. 8. 1. 1
			AD.ONLY Read only	1. 8. 1. 2
		SIGNAL Acoustic signal	OFF	1. 8. 2. 1
			o ON	1. 8. 2. 2
		KEYS Keypad	o FREE	1. 8. 3. 1
			LOCKED	1. 8. 3. 2
		EXT.KEY Function of the external switch	o PRINT key	1. 8. 4. 1
			Z/TARE key (TARE)	1. 8. 4. 2
			CAL key (CAL)	1. 8. 4. 3
			SELECT key (MENU)*	1. 8. 4. 4
CF key (CLEAR)	1. 8. 4. 5			
ENTER key	1. 8. 4. 9			
ON MODE Power-on mode	o OFF/ON Off/on/standby	1. 8. 5. 1		
	STANDBY On/standby	1. 8. 5. 2		
	AUTO ON Auto on	1. 8. 5. 3		
BACKLIT Display backlighting	OFF	1. 8. 6. 1		
	o ON	1. 8. 6. 2		
RESET Reset menu	MENU* Factory settings	YES Restore defaults	1. 9. 1. 1	
		o NO Do not restore defaults	1. 9. 1. 2	

* On some models, the keypad overlay shows the German word "MENUE" for MENU.

Level 1 [•]	Level 2 [••]	Level 3 [•••]	Level 4 [••••]	Menu code	
APPLIC. Applic. programs	WEIGH UNIT Toggle units	DISP.DIG. ¹⁾ Display accuracy	<input type="radio"/> ALL	2.1.	
			<input type="radio"/> MINUS 1	2.2.2.1 2.2.2.2	
	COUNTING	RESOLUT. Resolution	REF.UPDT. Autom. reference updating	<input type="radio"/> DISP.ACC. Display accuracy	2.3.1.1
				<input type="radio"/> 10-FOLD 10 times > disp.	2.3.1.2
		PERCENT Weighing in percent	DEC.PLCS Decimal places	<input type="radio"/> NONE No dec. places	2.3.2.1
				<input type="radio"/> AUTO	2.3.2.2
	NET-TOT Net-total	COMP.PRT. Component printout	DEC.PLCS Decimal places	<input type="radio"/> 1 DEC.PL. 1 decimal place	2.4.1.1
				<input type="radio"/> 2 DEC.PL. 2 decimal places	2.4.1.2
				<input type="radio"/> 3 DEC.PL. 3 decimal places	2.4.1.3
				<input type="radio"/> 3 DEC.PL. 3 decimal places	2.4.1.4
	TOTAL Totalizing	COMP.PRT. Component printout	DEC.PLCS Decimal places	<input type="radio"/> OFF	2.5.1.1
				<input type="radio"/> ON	2.5.1.2
	ANIMALW. Animal weighing	ACTIVITY. Animal activity	START	<input type="radio"/> OFF	2.6.1.1
				<input type="radio"/> ON	2.6.1.2
				<input type="radio"/> CALM (fluct.: 2% of test obj.)	2.7.1.1
	CALC. Calculation	METHOD (operator)	DEC.PLCS Decimal places	<input type="radio"/> ACTIVE (fluct.: 5% of test obj.)	2.7.1.2
				<input type="radio"/> V.ACTIVE (fluct.: 20% of test obj.)	2.7.1.3
		DENSITY Density determination	DEC.PLCS Decimal places	DEC.PLCS Decimal places	<input type="radio"/> MANUAL
<input type="radio"/> AUTO. Automatic					2.7.2.2
<input type="radio"/> MUL. Multiplier					2.8.1.1
<input type="radio"/> DIV. Divisor					2.8.1.2
DENSITY Density determination	DEC.PLCS Decimal places	DEC.PLCS Decimal places	<input type="radio"/> NONE No dec. places	2.8.2.1	
			<input type="radio"/> 1 DEC.PL. 1 decimal place	2.8.2.2	
			<input type="radio"/> 2 DEC.PL. 2 decimal places	2.8.2.3	
			<input type="radio"/> 3 DEC.PL. 3 decimal places	2.8.2.4	
DENSITY Density determination	DEC.PLCS Decimal places	DEC.PLCS Decimal places	<input type="radio"/> NONE No dec. places	2.9.1.1	
			<input type="radio"/> 1 DEC.PL. 1 decimal place	2.9.1.2	

¹⁾ Setting cannot be changed on verified balances



Input: ID number, Date and Time

Level 1 [•]	Level 2 [••]	Level 3 [•••]	Menu Code
INPUT Input	ID NO.	ID input for ISO/GLP compliant data record; 7 characters max. Permitted characters: 0 to 9; A to Z; dash/hyphen; space	3. 1.
	DATE	Menu item for setting the date	3. 2.
	TIME	Menu item for setting the time	3. 3.

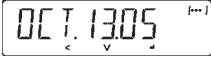
Depending on the setting you select for the menu item "SETUP-PRNT.OUT-DATE," the date will be displayed in the following format:

Format	Display: Date
DD.MMM.YY	
MMM.DD.YY	

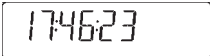
Depending on the setting you select for the menu item "SETUP-PRNT.OUT-TIME," the time will be displayed in the following format:

Time	Display: Time
24-hour format	
12-hour format	

Example: ID No., Date and Time

Step	Key (or instruction)	Display
1. Open the menu: In weighing mode; first menu item is displayed	(MENU)* hold	APPLIC.
2. Select "Input"	(MENU)*	INPUT
3. Select input for ID no.	twice (ENTER)	IDNO.
4. Set or change the ID no. — hold down key to automatically change the digit(s):	(MENU)* (MENU)* hold	3-----
5. Scroll within the 7-digit	(ENTER) or (CLEAR)	3-ABC 12
6. Save input when you have reached the last digit of the ID no.	(ENTER)	IDNO.
7. "Select "Date"	(MENU)*, (ENTER)	FEB.08.
8. Change setting — hold down key to automatically change the digit(s)	(MENU)* (MENU)* hold	FEB. 10.
9. Toggle between Day/Month/Year positions	(ENTER) or (CLEAR)	FEB. 10.
10. Save setting when you reach the "YEAR" position	(ENTER)	DATE
11. Select "Time"	(MENU)*, (ENTER)	10.46.23
12. Change setting — change the digit(s):	(MENU)* (MENU)* hold	11.46.23
13. Toggle between Hour/Minute/Second positions	(ENTER) or (CLEAR)	11.46.32
14. Set seconds to zero	(MENU)*	11.47.00
15. Save setting when you have reached the "second" position	(ENTER)	TIME
16. Save all settings and exit the menu	repeatedly (CLEAR)	
> Restart your application		0.0 g

* On some models, the keypad overlay shows the German word "MENUE" for MENU.

Device Information

Level 1 [•]	Level 2 [••]	Level 3 [•••]	Example	Menu code
INFORMATION	VERSION	Show software version	REL.36.03	4.1.
	SER. NO.	Show serial number To toggle focus between upper and lower display sections, press (MENU)*	1080 1234	4.2.
	MODEL	Show model designation (to change focus from upper to middle to lower display section and back, press (MENU)*	ATL-820 1	4.3.

Display of Menu Items: Text or Codes

LANGUAGE	ENGLISH	(factory setting)	5.1.
	DEUTSCH	German	5.2.
	FRANC.	French	5.3.
	ITAL.	Italian	5.4.
	ESPAÑOL	Spanish	5.5.
	РУССКИЙ	Russian	5.6.
	POLSKI	Polish	5.7.
	CODES	Menu shows codes (not texts)	5.8.

Application Programs

Using Verified Balances as Legal Measuring Instruments in the EU*:

All application programs can be selected on balances used as legal measuring instruments.

Calculated values are alternately indicated with the following symbols:

- Percent = %
- Piece count (Counting) = pcs
- Computed value = 0, 

* On some models, the keypad overlay shows the German word "MENUE" for MENU.

Counting

Display symbol: 

Purpose

With the Counting program you can determine the number of parts that each have approximately equal weight. To do this, a known number of parts (the reference sample quantity) is weighed first, and the individual piece weight (reference weight) is calculated from this result. Thus the number of parts subsequently placed on the balance can be determined from their weight.

Preparation

- Select the Counting application in the menu: see “Configuration.”
- Set the following parameters:

APPLIC. Application program

```
COUNT.  
├── RESOLUT. Resolution  
│   ├── 0 DISP.ACC. Display accuracy  
│   └── 10-FOLD 10-fold higher  
├── REF.UPDT. Autom. ref. sample updating  
│   ├── 0 OFF Display accuracy  
│   └── AUTOM. Automatic
```

0 = Factory setting

Changing the Reference Sample Quantity

Activate function:

Press the (MENU)* key

Select the desired reference sample quantity (1 to 100):

In increments of 1: Press the (MENU)* key briefly

In increments of 10:

Press and hold the (MENU)* key.

The quantity is stored in battery-backed memory.

Reference Sample Updating

Automatic reference sample updating

optimizes the counting accuracy.

You can activate or deactivate this function in the menu.

Automatic reference sample updating

is performed when the requirements,

including the specified stability criterion, have been met.

The abbreviation *OPT*, for “optimizing”, is displayed briefly with the new reference sample quantity.

Printout: Counting

nRef	+	10	: Reference sample quantity
wRef	+	21.14 g	: Reference weight
Qnt	+	500 pcs	: Calculated quantity

* On some models, the keypad overlay shows the German word “MENUE” for MENU.

Example : Counting parts of equal weight

Parameter: *APPLIC. - COUNT.* (menu code 2. 3.)

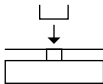
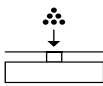
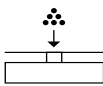
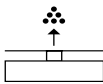
Step	Key (or instruction)	Display/Data output
1. Place empty container on the balance		+ 22.6 g
2. Tare the balance	(TARE)	0.0 g
3. Add reference sample quantity to container (in this example: 20 pcs)		
4. Changing the reference sample quantity:	(MENU)*	REF 10 pcs
5. Select reference sample quantity: In increments of 1 (1, 2, 3, etc. to 100) In increments of 10 (10, 20, etc. to 100)	Repeatedly: (MENU)* Press briefly (MENU)* press and hold	REF 20 pcs
6. Confirm selected reference sample quantity and start application. The current reference weight remains stored until a new reference weight remains stored until a new reference is set or the power supply is interrupted	(ENTER)	+ 20 pcs * nRef 20 pcs wRef 1.07 g
7. Add desired number of pieces.		+ 500 pcs
8. If desired, print quantity	(PRINT)	Qnt + 500 pcs
9. Toggle display between mean piece weight, weight, quantity	Repeatedly: (MENU)*	1.07 g Δ* + 535.0 g * + 500 pcs *
10. Unload the balance		- 2 pcs *
11. Repeat as needed, starting from step 7		
12. Delete reference value	(CLEAR)	0.0 g

* On some models, the keypad overlay shows the German word "MENUE" for MENU.

Weighing in Percent

Display symbol: %

Purpose

This application program allows you to obtain weight readouts in percent which are in proportion to a reference weight.

Preparation

- Select the Weighing in percent application in the menu: see "Configuration."
- Set the following parameters:

```
APPLIC. Application program
├── PERCENT Weighing in percent
│   ├── DEC.PLCS. Decimal places
│   │   ├── NONE No decimal places
│   │   ├── 0 1 DEC.PL. 1 decimal place
│   │   ├── 2 DEC.PL. 2 decimal places
│   │   └── 3 DEC.PL. 3 decimal places
```

0 = Factory setting

Changing the Reference Percentage

Activate function:

Press the (MENU)* key

Select the desired reference (1 to 100):

In increments of 1: Press the (MENU)* key briefly

In increments of 10: Press and hold the (MENU)* key.

The percentage is stored in battery-backed memory.

Printout: Weighing in percent

pRef	100	: Reference percentage
Wxx%	111.6 g	: Reference weight net xx% for selected reference percentage
PrC	+ 94.9 %	: Calculated reference percentage

* On some models, the keypad overlay shows the German word "MENUE" for MENU.

Example: Determining residual weight in percentParameter settings: *APPLIC. PERCENT* (menu code 2. 4.)Reference percentage: *REF 100%*

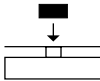
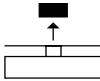
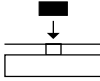
Step	Key (or instruction)	Display/Data output
1. Tare the balance	(TARE)	0.0 g
2. Place sample equal to 100% on the balance (in this example: 111.6 g)		
3. Information: Enter reference percentage (Changing the reference: see the previous page)	(MENU)*	<i>REF 100 %</i>
4. Initialize the balance The current reference weight remains stored until a new reference is set or the power supply is interrupted	(MENU)*	+ 100.0 % * pRef 100 % Wxx% + 111.6 g
5. Remove sample (e.g., for drying)		
6. Place unknown weight on balance (in this example: 105.9 g)		+ 94.9 % *
7. If desired, print percentage	(PRINT)	Prc + 94.9 %
8. Toggle display between weight and percentage	Repeatedly: (MENU)*	+ 105.9 g * + 94.9 % *
9. Clear display of residual weight and reference percentage	(CLEAR)	+ 105.9 g
10. If desired, print net residual weight	(PRINT)	N + 05.9 g

* On some models, the keypad overlay shows the German word "MENUE" for MENU.

Calculation

Display symbol: C

Purpose

With this application program you can calculate weight value using a multiplier or divisor. This can be used, for example, to determine the weight per unit area, or "gsm" weight (grams per square meter), of paper.

Preparation

- Select the Calculation application in the menu: see "Configuration."
- Set the following parameters:

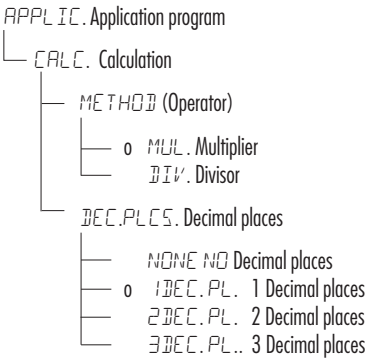

0 = Factory setting

Setting the Factor or Divisor

Activate function:

Press the (MENU)* key

Select a number of up to 7 digits and, if needed, one decimal point (0.000001 to 9999999):

In increments of 1: Press the (MENU)* key briefly

To increase the value without pressing repeatedly:

Press and hold the (MENU)* key.

The selected operator is stored in battery-backed memory.

Printout: Calculation

MuL	+	1.2634	:	Multiplier
Div	+	0.6237	:	Divisor
Res	+	79.7	o	: Result

* On some models, the keypad overlay shows the German word "MENUE" for MENU.

Example:

Calculating the weight per unit area of paper: An A4 sheet of paper is used in this example, with surface dimensions of 0.210 m + 0.297 m = 0.06237 m². To determine the weight per unit area, the total weight is divided by the surface.

Parameter settings:

APPLIC. CALC.-METHOD-DIV. (menu code 2. 8. 1. 2)

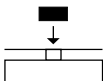
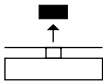
Step	Key (or instruction)	Display/Data output
1. Tare the balance	(TARE)	0.00 g
2. Activate divisor input	(MENU)*	-----0.
3. Set the divisor (in this example: 0.06237): Position the decimal point, Enter numerals	(ENTER), 5× (MENU)*, 2× (ENTER), Repeatedly (MENU)* or press and hold: (ENTER), etc.	 --.00000 --.06000 --.06237
4. Store the divisor and initialize the balance The current divisor remains stored in battery-backed memory until the setting is changed	(ENTER)	+ 0.0 ⁰ Div 0.6237
5. Weight per unit area: Place an A4 sheet of paper on the balance		+ 79.7 ⁰ *
6. If desired, print result	(PRINT)	Res + 79.7 ⁰
7. Toggle display between weight and calculated value	Repeatedly: (MENU)*	+ 4.976 * + 79.7 ⁰ *
8. Unload the balance		+ 0.0 ⁰ *
9. Repeat as needed, starting from Step 5		

* On some models, the keypad overlay shows the German word "MENUE" for MENU.

Animal Weighing/Averaging

Display symbol: 

Purpose

Use this program to determine the weights of unstable samples (e.g., live animals) or to determine weights under unstable ambient conditions. With this program, the balance calculates the weight as the average of a defined number of individual weighing operations (also referred to as “subweighing operations”).

Preparation

- Select the Animal weighing application in the menu: see “Configuration.”
- Set the following parameters:

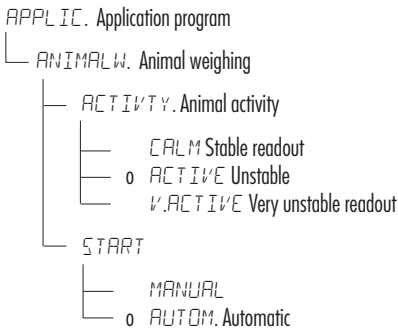

0 = Factory setting

Changing the Number of Subweighing Operations

Activate function:
Press the (MENU)* key
Select the desired number of measurement (1 to 100):
In increments of 1:
Press the (MENU)* key briefly
In increments of 10:
Press and hold the (MENU)* key.

The selected number of measurements is stored in battery-backed memory

Printout: Animal weighing

m D e f	20	: Number of subweighing operations
x - N e t +	410.1 g	: Calculated average

* On some models, the keypad overlay shows the German word “MENUE” for MENU.

Example: Determining animal weight with automatic start and 20 subweighing operations (measurements)

Parameter settings: *APPLIC. ANIMALW.* (menu code 2.7.)

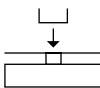
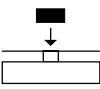
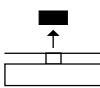
Step	Key (or instruction)	Display/Data output
1. Place animal weighing bowl on the balance		22.6 g
2. Tare the balance	(TARE)	0.0 g
3. Change the number of subweighing operations:	(MENU)*	REF 30
4. Set number of measurements: In increments of 1 (1, 2, 3, etc. to 100) In increments of 10 (10, 20, etc. to 100)	Repeatedly: (MENU)* Press briefly or (MENU)* and hold	REF 20
5. Confirm number of measurements and start automatic animal weighing. The number of measurements remains stored in battery-backed memory until the setting is changed	(ENTER)	+ 0.0 g*
6. Place first animal in bowl. The balance delays the start of measurements until the difference between 2 measurements meets the criterion		888 20 19 ... 1
○ If you selected the manual start mode, press	(ENTER)	
7. Read off the result The result is displayed with the "Δ" symbol (= calculated value) and remains displayed until the sample (animal) is removed from the load plate (bowl)		+ 410.1 g Δ* mDef 20 x-Net + 410.1 g
8. Unload the balance		+ 0.0 g*
9. Weigh next animal (if desired) Next weighing series begins automatically		

* On some models, the keypad overlay shows the German word "MENUE" for MENU.

Net-total Formulation

Display symbol: 

Purpose

With this application program you can weigh in individual components either by their individual weight or by the total weight. You can print out both the total weight and the individual weights of the components.

Preparation

- Select the Net-total application in the menu: see "Configuration."
- Set the following parameters:

```
APPLIC. Application program
├── NET-TOTL. Net-total formulation
│   ├── COMP.PRT. Printout of components
│       ├── OFF
│       └── 0 ON
```

o = Factory setting

Features

- Weigh up to 99 components from "0" to a defined total component weight.
- Store component weights
(printout shows "Comp xx" with
 - display zeroed automatically after value is stored, and
 - automatic printout
- Clear component memory following cancellation of the weighing sequence (by pressing) and printout of the total weight.
- Toggling between component weight and total weight by pressing and holding (MENU)*. (< 2 sec).
- Printout of the total of the individual component weights (T-Comp)

Printout: Net-total formulation

```
Comp 2+ 278.1 g : Second component
T-Comp+2117.5 g : Sum of components
```

* On some models, the keypad overlay shows the German word "MENUE" for MENU.

Example: Counting parts into a container

Parameter settings:

APPLIC.-NET-TOT (menu code 2. 5.)

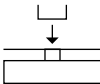
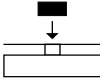
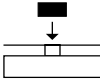
Step	Key (or instruction)	Display/Data output
1. Place empty container on the balance.		65.0 g
2. Tare the balance	(TARE)	0.0 g
3. Add first component		+ 120.5 g
4. Store component data	(ENTER)	+ 0.0 g * NET Comp 1+ 120.5 g
5. Add next component		+ 70.5 g * NET
6. Store component data	(ENTER)	+ 0.0 g * NET Comp 2+ 70.5 g
7. Weigh in further components as desired	Repeat steps 5 and 6	
8. Fill to desired final value view the current total weight value	(MENU)*	+ 191.0 g *
9. Print total weight and clear the component memory	(CLEAR)	+ 2117.5 g T-Comp+ 2117.5 g

* On some models, the keypad overlay shows the German word "MENUE" for MENU.

Totalizing

Display symbol: 

Purpose

With this application program you can add values from successive, mutually independent weight values to a total that exceeds the capacity of the balance.

Preparation

- Select the Totalizing application in the menu: see “Configuration”.
- Set the following parameters:

```
APPLIC. Application program
├── TOTAL Totalizing
│   ├── COMP.PRT Printout of components
│   │   ├── OFF
│   │   └── 0 ON
```

0 = Factory setting

Features

- Totalizing memory for up to 99 values
- Store component weights (printout shows “Comp x x” with automatic printout)
- Toggle display between the current individual weight value and the value in totalizing memory by pressing (MENU)*.
- Printout of the total of the individual component weights (S-Comp)
- To close the application program and print the total weight: press (CLEAR)

Printout: Totalizing

Comp 2+ 278.1 g	: Second component
S-Comp+2117.5 g	: Totalizing memory

* On some models, the keypad overlay shows the German word “MENUE” for MENU.

Example: Totalizing weight values

Parameter settings:

APPLIC. TOTAL COMP.PRT ON (Code 2. 6. 1. 2)

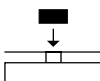
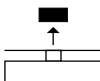
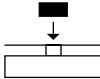
Step	Key (or instruction)	Display/Data output
1. Tare the balance	(TARE)	0.0 g
2. Place sample balance (in this example: 380 g)		+ 380.0 g
3. Store value in memory	(ENTER)	+ 380.0 g * Comp 1+ 380.0 g
4. Remove sample		+ 0.0 g *
5. Place the next sample on the balance (in this example, 575 g)		+ 575.0 g *
6. Store value in memory	(ENTER)	+ 955.0 g * + 575.0 g * Comp 2+ 575.0 g
7. View the value in totalizing memory	(ENTER)	+ 955.0 g Δ *
8. Weigh in further components as desired	Repeat steps 5 and 6	
9. Print total weight and clear the totalizing memory	(CLEAR)	0.0 g S-Comp+ 2117.5 g

Density Determination

Display symbol: $\Delta \bar{\Delta}$

Purpose

This application program lets you determine the density of solid substances using the buoyancy method. You can have results displayed with one decimal place, or no decimal places: see "Configuration".

Note: the sample holder and suspension wire used in the example below are not included with the balance.

Preparation

- Select the Density Determination application in the menu: see "Configuration."
- Set the following parameters:

APPLIC. Application program

└ DENSITY Density determination

└ DEC.PLCS Decimal places

└ NONE No decimal places
└ 0 DEC.PL 1 decimal place

o = Factory setting

Printout for Density Determination

W a	+	20.0 g	: Weight in air
W f L	+	15.0 g	: Weight in liquid
R h o		4.0 o	: Result: density of the sample

Example: Determining the density of a solid sample.

Parameter settings:

APPLIC.-DENSITY-BEC.PLCS-1 BEC.PL (menu code 2.9.1.2)

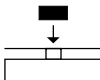
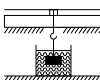
Step	Key (or instruction)	Display/Data output
1. Attach sample holder to suspension wire		
2. Tare the balance	(TARE)	0.0 g
3. Start application program	(ENTER)	
4. Confirm "AIR" display	(ENTER)	AIR ?
5. Determine the weight of the sample in air: Place sample on the balance		+ 20.0 g *
6. Store value for weight in air	(ENTER)	
7. Remove sample from the balance		WATER ?
8. Determine weight in liquid: place sample in holder		
9. Confirm "WATER" display	(ENTER)	0.0 g *
10. Immerse sample in liquid		+ 15.0 g *
11. Store value for weight in liquid, view result, and print	(ENTER)	+ 4.0 ⁰ *
		Wa + 20.0 g
		Wfl + 15.0 g
		Rho 4.00
12. Delete result	(CLEAR)	
13. Repeat as desired, starting from Step 3.		

Mass Unit Conversion

Purpose

With this application program you can change the weight value displayed from the basic weight unit to any of 4 application weight units (see table on next page).

Preparation

- Select the Unit application for toggling weight units: see chapter on "Configuration" (Parameter Settings)
- Set the following parameters:

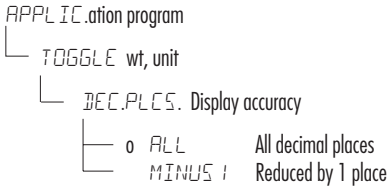

0 = Factory setting

Features

- Set the basic unit and display accuracy in the Setup menu: see "Configuration."
- Set the application weight units and display accuracies in the Application menu.
- These settings are stored in battery-backed memory.
- The basic unit is active when the balance is powered up.

Printout for Wt. Unit Toggling

+ 100.0 g	: Weight with 16-character data output format
N + 0.22046 lb	: Weight with 22-character data output format
13-Jan-2005 08:35	: Data output format for two-line printout:
N + 3.5275 oz t	: Date/time and weight

Example: Change display from the basic unit (in this example, grams [g]) to pounds [lb] and then to Troy ounces [ozt].

Set the following parameters: *APPLIC. UNIT* (Code 2. 2.)

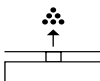
Step	Key (or instruction)	Display
Preparation:		
1. Begin selection of an application weight unit	(MENU)*	NONE ⁰ [•]
2. Select an application unit; in this example, pounds (see table on next page)	Repeatedly: (MENU)*	POUND
3. Confirm the weight unit (pounds)	(ENTER)	POUND ⁰
4. Select the next application weight unit; in this example: Troy ounces (see table on next page)	(ENTER) Repeatedly: (MENU)*	KEINE ⁰ [••] TROY.OZ.
5. Confirm weight unit (Troy ounces)	(ENTER)	TROY.OZ. ⁰
6. Select other application units if desired (max. 4 total) (otherwise, confirm <i>NONE</i> by pressing)		[•••]
7. Save selection	(CLEAR)	0.00 g
Conversion:		
8. Place sample on balance		+ 100.00 g
9. Toggle unit for weight value	Repeatedly: (ENTER)	+ 0.22046 lb + 3.5275 ozt

* On some models, the keypad overlay shows the German word "MENUE" for MENU.

The following weight units are available in your Atilon balance (in legal metrology, only units permitted by national law are available):

Menu item	Unit	Conversion factor	Display symbol
1) <i>USERDEF. 1)</i>	Grams	1,0000000000	o
2) <i>GRAMS</i> (factory setting)	Grams	1.0000000000	g
3) <i>KILOGR.</i>	Kilograms	0.0010000000	kg
4) <i>CARRATS</i>	Carats	5.0000000000	o
5) <i>POUNDS</i>	Pounds	0.00220462260	lb
6) <i>OUNCES</i>	Ounces	0.03527396200	oz
7) <i>TROY OZ.</i>	Troy ounces	0.03215074700	ozt
8) <i>HK TAEI</i>	Hong Kong taels	0.02671725000	tl
9) <i>SING. TAEI</i>	Singapore taels	0.02645544638	tl
10) <i>TWN. TAEI</i>	Taiwanese taels	0.02666666000	tl
11) <i>GRAINS</i>	Grains	15.4323583500	GN
12) <i>PENNY WT.</i>	Pennyweights	0.64301493100	dwt
13) <i>MILLIGR.</i>	Milligrams	1000.00000000	mg
14) <i>PT. P. LB.</i>	Parts per pound	1.12876677120	o
15) <i>CHN. TAEI</i>	Chinese taels	0.02645547175	tl
16) <i>MOMMES</i>	mommes	0.26670000000	m
17) <i>AUSTRICT.</i>	Austrian carats	5.0000000000	Kt
18) <i>TOLA</i>	Tola	0.08573333810	o
19) <i>BAHT</i>	Baht	0.06578947436	b
20) <i>MESGHAL</i>	Mesghal	0.21700000000	o
21) <i>TONS</i>	Tons	0.00000100000	t
22) <i>LB / OZ 2)</i>	Pounds : ounces	0.03527396200	lb oz
23) <i>NEWTON</i>	Newton	0.00980665000	N

1) = User-defined weight unit; can be loaded in the balance over an optional RS-232 or USB interface using a computer program.

2) = The format for display of pounds/ounces cannot be changed: xx:yy.yy x=lb, y=oz

⚠ Some weight units may be blocked from use in legal metrology, depending on national verification laws.

ISO/GLP-compliant Printout/Record

Features

You can have device information, ID texts and date and time printed before (GLP header) and after (GLP footer) the values of a weighing series. These parameters include:

- GLP header:
- Date
 - Time at beginning of measurement
 - Balance manufacturer
 - Balance model
 - Balance serial number
 - Software version number
 - Identification number of the current sampling operation

- GLP footer:
- Date
 - Time at end of measurement
 - Field for operator signature

△ Operating the Balance with Printer:

(e.g. YDPO3-OCE):

- Select the following settings on the balance and on the printer:
 - Software handshake:
`SETUP INTERF. HANDSHK. SOFTWARE`
(menu code 1. 5. 4. 1)

Configuration

- Setting menu codes for the printout (see “Configuration”):
 - ISO/GLP-compliant printout or record only for calibration/adjustment:
`SETUP PRINTOUT GLP CAL.-ADJ.`
(menu code 1. 6. 7. 2) or
ISO/GLP-compliant printout or record always on:
`SETUP PRINTOUT GLP ALWAYS ON`
(menu code 1. 6. 7. 3)

- Line format for printout: include data ID codes (22 characters; factory setting):
`SETUP PRINTOUT FORMAT 22CHAR.`
(menu code 1. 6. 6. 2)
- Formats for time:
`SETUP PRINTOUT TIME 24H`
(menu code 1. 6. 8. 1) or
`SETUP PRINTOUT TIME 12H`
(menu code 1. 6. 8. 2)
- Formats for date:
`SETUP PRINTOUT DATE DDMMYY`
(menu code 1. 6. 9. 1) or
`SETUP PRINTOUT DATE MMM.DD.YY`
(menu code 1. 6. 9. 2)

- △ No ISO/GLP-compliant record is output if any of the following settings are configured:
`SETUP PRINTOUT PRINT AUT.W/O` or
`PRINT WITH` (menu code 1. 6. 1. 3, 1. 6. 1. 4,) or
`FORMAT 16CHAR.` (menu code 1. 6. 6. 1)

Function Keys

Transfer header and first measured value: press (PRINT)

- > The header is included with the first printout/data record.

To output header and reference data automatically when an application program is active: press

Exit the application:

- 1) To send the GLP footer: press (CLEAR)
- 2) Quit application program: press (CLEAR) again

The ISO/GLP-compliant printout can contain the following lines:

-----	Dotted line
17-Aug-2006 10:15	Date/time (beginning of measurement)
ACCULAB	Balance manufacturer
Mod. ATL-8201	Model
Ser. no. 10105355	Balance serial number
Ver. no. 00-36-01	Software version
ID 2690 923	ID
-----	Dotted line
L ID	Measurement series no.
nRef 10 pcs	Counting: reference sample quantity
wRef 21.14 g	Counting: reference weight
Qnt + 567 pcs	Counting result
-----	Dotted line
17-Aug-2006 10:20	Date/time (end of measurement)
Name:	Field for operator signature
Blank line	
-----	Dotted line

ISO/GLP-compliant printout for external calibration/adjustment:

-----	Dotted line
17-Aug-2006 10:30	Date/time (beginning of measurement)
ACCULAB	Balance manufacturer
Mod. ATL-8201	Model
Ser. no. 10105352	Balance serial number
Ver. no. 00-36-01	Software version
ID 2690 923	ID
-----	Dotted line
Cal. Ext. Test	Calibration/adjustment mode
Set + 5000.0 g	Calibration weight
Diff. + 0.2 g	Difference determined in calibration
Cal. Ext. Complete	Confirmation of completed calibration procedure
Diff. 0.0 g	Difference from target following adjustment
-----	Dotted line
17-Aug-2006 10:32	Date/time (end of measurement)
Name:	Field for operator signature
Blank line	
-----	Dotted line

Data Interface

Purpose

Your balance comes equipped with an interface port for connection to a computer or other peripheral device. You can use a computer to change, start and/or monitor the functions of the balance and the application programs.

Preparation

You can set these parameters for other devices in the Setup menu (see the chapter entitled "Configuring the Balance").

You will also find a detailed description of the available data interface commands in the file "Data Interface Descriptions for ATL Models", which you can download from the Acculab website at www.acculab.com by selecting "Download Instruction Manuals" from the "Service" menu.

Female Interface Connector:

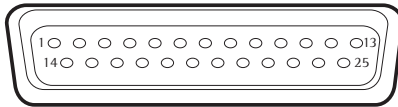

25-contact female connector, RS-232:

- Pin 1: Signal ground
- Pin 2: Data output (TxD)
- Pin 3: Data input (RxD)
- Pin 4: Internal ground (GND)
- Pin 5: Clear to send (CTS)
- Pin 6: Not connected
- Pin 7: Internal ground (GND)
- Pin 8: Internal ground (GND)
- Pin 9: Not connected
- Pin 10: Not connected
- Pin 11: + 12 V
(power supply for Sartorius printer)
- Pin 12: Reset _ Out *)
- Pin 13: + 5 V
- Pin 14: Internal ground (GND)
- Pin 15: Universal remote switch
- Pin 16: Not connected
- Pin 17: Not connected
- Pin 18: Not connected
- Pin 19: Not connected
- Pin 20: Data terminal ready (DTR)
- Pin 21: Not connected
- Pin 22: Not connected
- Pin 23: Not connected
- Pin 24: Not connected
- Pin 25: +5 V

*) = Hardware restart

The many and versatile properties of these balances can be fully utilized for printing out records of the results when you connect your balance to an Acculab data printer. The recording capability for printouts makes it easy for you to work in compliance with ISO/GLP.

For remote switch

Troubleshooting Guide

Error codes are shown on the main display for approx. 2 seconds.
The program then returns automatically to the previous mode.

Display	Cause	Solution
No segments appear on the display	No AC power is available The power supply is not plugged in	Check the AC power supply Plug in the power supply
<i>HIGH</i>	The load exceeds the balance capacity	Unload the balance
<i>LOW</i> or <i>ERR 54</i>	Something is touching the weighing pan	Move the object that is touching the weighing pan
<i>ERR 54</i> , typical	Weighing system defect	Contact Acculab dealer
<i>APP.ERR.</i>	Cannot store data: Load on weighing pan too light or no sample on pan while application is active	Increase load
<i>DIS.ERR.</i>	Data output not compatible with output format	Change the configuration in the operating menu
<i>PRT.ERR.</i>	Interface port for printer output is blocked	Reset the menu factory settings, or Contact Acculab dealer
<i>ERR 02</i>	Calibration parameter not met; e.g.: – balance not tared – load on weighing pan	Calibrate only when zero is displayed – Press [Tare] to tare the balance – Unload the balance
<i>ERR 10</i>	The [Tare] key is blocked when there is data in the second tare memory (net-total); only 1 tare function can be used at a time	Press [Clear] to clear the tare memory and release the tare key
<i>ERR 11</i>	Tare memory not allowed	Press [Tare]
The weight readout changes constantly	Unstable ambient conditions (excessive vibration or draft) at the place of installation A foreign object is caught between weighing pan and balance housing	Set up the balance in another area Remove the foreign object
The weight readout is obviously wrong	The balance was not calibrated/adjusted Balance not tared before weighing	Calibrate/adjust the balance Tare or zero the balance before weighing

Care and Maintenance

Repairs

- Repair work must be performed by trained service technicians. Any attempt by untrained persons to perform repairs may result in considerable hazards for the user. If the instrument requires repairs, please contact your Acculab dealer.

Cleaning

- Unplug the AC adapter from the wall outlet (mains supply). If you have an interface cable connected to the balance port, unplug it from the port.

- ⚠ Make sure that no liquid enters the balance/scale housing.
- ⚠ Do not aggressive cleaning agents (solvents or similar agents).
- After cleaning, wipe down the balance with a soft, dry cloth.

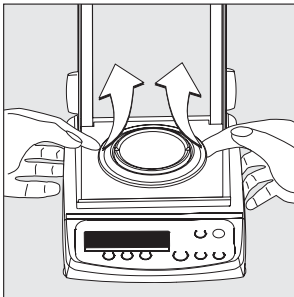

On analytical balances remove and clean the weighing pan as follows:

- Reach beneath the drip/breeze and lift it carefully, together with the pan support, to avoid damaging the weighing system.
- ⚠ Make sure that no liquid enters the balance housing.

Cleaning Stainless Steel Surfaces

Clean all stainless steel parts regularly. Remove the stainless steel weighing pan and thoroughly clean it separately. Use a damp cloth or sponge to clean stainless steel parts on the balance. You can use any household cleaning agent that is suitable for use on stainless steel. Clean stainless steel surfaces only by wiping them down. Then rinse the equipment thoroughly, making sure to remove all residues. Afterwards, allow the equipment to dry. If desired, you can apply oil to the cleaned surfaces as additional protection.

Recycling

Safety Inspection

If there is any indication that safe operation of the balance is no longer warranted:

- Turn off the power and disconnect the equipment from AC power immediately.
- > Lock the equipment in a secure place to ensure that it can not be used for the time being.

Notify your Acculab dealer. Repair work must be performed by trained service technicians.

We recommend having the power supply inspected by a certified electrician at regular intervals, according to the following checklist:

- Insulating resistance: > 7 megaohms measured with a constant voltage of at least 500 volts at a 500 K-ohm load
- Leakage current: < 0.05 mA measured with a properly calibrated multimeter

Information and Instructions on Disposal and Repairs
Packaging that is no longer required must be disposed of at the local waste disposal facility. The packaging is made of environmentally friendly materials that can be used as secondary raw materials.



The equipment, including accessories and batteries, does not belong in your regular household waste. The EU legislation requires its Member States to collect electrical and electronic equipment and dispose of it separately from other unsorted municipal waste with the aim of recycling it.

For disposal in Germany and in the other Member States of the European Economic Area (EEA), please contact our service technicians on location or your Acculab dealer.

In countries that are not members of the European Economic Area (EEA) or where no Acculab dealers are located, please contact your local authorities or a commercial disposal operator.

Prior to disposal and/or scrapping of the equipment, any batteries should be removed and disposed of in local collection boxes.

Equipment contaminated with hazardous materials (ABC contamination) will not be taken back; neither for repair or disposal.

Overview

Specifications

Built-in motorized calibration weight		All ATL...-I and ATL...-V models
AC power source/power requirements, voltage, frequency		AC adapter 230 V or 115 25 V, +15% to -20%, 48 - 60 Hz
Power consumption	VA	maximum 16; typical 8 (STNG6)
Approx. hours of operation with the YRB05Z rechargeable battery pack (backlighting on)	h	35

Specifications for Individual Models

Model		ATL-224, ATL-224-I	ATL-124, ATL-224-I
Weighing capacity	g	220	120
Readability	g	0.0001	0.0001
Tare range (subtractive)	g	220	120
Repeatability (std. deviation)	≤± g	0.0001	0.0001
Linearity	≤± g	0.0002	0.0002
Response time (average)	s	2.5	
Sensitivity drift within +10 to +30°C	≤±/K	2 · 10 ⁻⁶	
Adaptation to ambient conditions		By selection of 1 of 4 optimized filter levels; display update: 0.1 – 0.4 (depends on filter level selected)	
External calibration weight	g	200 (E2)	100 (E2)
Operating temperature range		+10 ... +30 °C (273 ... 303 K, 50° ... 86 °F)	
Net weight, approx.:	kg	4.4 4.7	
Weighing pan size	mm	90 Ø	
Weighing chamber height	mm	230	
Dimensions (W × D × H)	mm	230 × 303 × 330	

Model		ATL-623, ATL-623-I	ATL-423, ATL-423-I	ATL-153, ATL-153-I
Weighing capacity	g	620	420	150
Readability	g	0.001	0.001	0.001
Tare range (subtractive)	g	620	420	150
Repeatability (std. deviation)	≤± g	0.001	0.001	0.001
Linearity	≤± g	0.002	0.002	0.003
Response time (average)	s	1	1	1.3
Sensitivity drift within +10 to +30°C	≤±/K	2 · 10 ⁻⁶	2 · 10 ⁻⁶	5 · 10 ⁻⁶
Adaptation to ambient conditions		By selection of 1 of 4 optimized filter levels; display update: 0.05 – 0.4 (depends on filter level selected)		
External calibration weight (of at least accuracy class...)	g	500 (E2)	200 (F1)	100 (F1)
Operating temperature range		+10 ... +30 °C (273 ... 303 K, 50° ... 86 °F)		
Net weight, approx.:	kg	3.2 3.6	3.2 3.6	2.6 3.0
Weighing pan size	mm	115 Ø		
Dimensions (W × D × H)	mm	230 × 303 × 136		

Specifications for Individual Models

Model		ATL-6202, ATL-6202-I	ATL-4202, ATL-4202-I	ATL-2202, ATL-2202-I	ATL-822, ATL-822-I
Weighing capacity	g	6200	4200	2200	820
Readability	g	0.01	0.01	0.01	0.01
Tare range (subtractive)	g	6200	4200	2200	820
Repeatability (std. deviation)	≤ ± g	0.01	0.01	0.01	0.01
Linearity	≤ ± g	0.02	0.02	0.02	0.03
Response time (average)	s	1.1	1.1	1.1	1.0
Sensitivity drift within +10 to +30°C	≤ ± /K	2 · 10 ⁻⁶	2 · 10 ⁻⁶	2 · 10 ⁻⁶	5 · 10 ⁻⁶
Adaptation to ambient conditions		By selection of 1 of 4 optimized filter levels; display update: 0.1–0.4 (depends on filter level selected)			
(of at least accuracy class...)	g	5000 (E2)	2000 (E2)	2000 (F1)	500 (F2)
Operating temperature range		+10 ... +30 °C (273 ... 303 K, 50° ... 86 °F)			
Net weight, approx.:	kg	3.1 3.5	3.1 3.5	3.1 3.5	2.0 2.6
Weighing pan size	mm	180×180	180×180	180×180	115 Ø
Dimensions (W × D × H)	mm	230×303×91			230×303×87

Model		ATL-8201, ATL-8201-I	ATL-6201, ATL-6201-I
Weighing capacity	g	8200	6200
Readability	g	0.1	0.1
Tare range (subtractive)	g	8200	6200
Repeatability (std. deviation)	≤ ± g	0.1	0.1
Linearity	≤ ± g	0.3 0.1	0.3 0.1
Response time (average)	s	1	1
Sensitivity drift within +10 to +30°C	≤ ± /K	10 · 10 ⁻⁶	
Adaptation to ambient conditions		By selection of 1 of 4 optimized filter levels; display update: 0.05 – 0.4 (depends on filter level selected)	
External calibration weight (of at least accuracy class...)	g	5000 (F2)	
Operating temperature range		+10 ... +30 °C (273 ... 303 K, 50° ... 86 °F)	
Net weight, approx.:	kg	2.7 3.5	
Weighing pan size	mm	180×180	
Dimensions (W × D × H)	mm	230×303×91	

Accessories

External calibration weights:

For model	Accuracy class	Weight in grams	Order no.
ATL-224	E2	200	YCW5228-00
ATL-124	E2	100	YCW5128-00
ATL-623	E2	500	YCW5528-00
ATL-4202	E2	2000	YCW6228-00
ATL-6202	E2	5000	YCW6528-00
ATL-153	F1	100	YCW5138-00
ATL-423	F1	200	YCW5238-00
ATL-2202	F1	2000	YCW6238-00
ATL-822	F2	500	YCW5548-00
ATL-8201, ATL-6201	F2	5000	YCW6548-00
or	± 25 mg	5000	YSS653-00

Product

Data printer

with date, time, statistics evaluation, transaction counter functions and LCD

Order No.

YDPO3-OCE

Remote display¹⁾, reflective

(for connection to data interface port)

YRD02Z

External rechargeable battery pack YRB05Z

With battery-level indicator (LED); can be recharged using the AC adapter (charge time for completely discharged battery pack: 15 hours); see "Specifications" for hours of operation. To recharge the battery pack: Unplug the AC adapter from the balance and plug it into the battery pack

SartoConnect¹⁾

data transfer software for direct transmission of weight values to another program (e.g., MS Excel)

- with RS-232C connecting cable, length: 1 m (~20 in) YSC01L
- with RS-232C connecting cable, length: 5 m (~16 ft) YSC01L5
- with RS-232C connecting cable, length: 15 m (~50 ft) YSC01L15

Product

Density determination kit¹⁾

- for ED224S, ED124S

Order No.

YDK01LP

Industrial AC adapter, model ING2,

protection rating: IP65 in accordance with EN 60529

- for 230 V 69 71899
- for 120 V 69 71500

Data cable

- for connecting a computer with a USB port YCC01-USBM2
- for computer connection, 25-pin 7357312
- for computer connection, 9-pin 7357314

Adapter cable

from D-Sub 25-pin male connector to D-Sub 9-contact female connector; length: 0.25 m

6965619

Anti-theft locking device

LC-1

¹⁾ Not for verified models

CE Marking

The balance complies with the following EC Directives and European Standards:

Council Directive 89/336/EEC
“Electromagnetic compatibility (EMC)”

Applicable European Standards:

Limitation of emissions:

In accordance with product standard EN 61326-1 Class B (residential area)

Defined immunity to interference:

in accordance with product standard EN 61326-1 (minimum test requirements, non-continuous operation)

Important Note:

The operator shall be responsible for any modifications to Acculab equipment and must check and, if necessary, correct these modifications.

On request, Sartorius will provide information on the minimum operating specifications (in accordance with the Standards listed above for defined immunity to interference).

73/23/EEC “Electrical equipment designed for use within certain voltage limits”

Applicable European Standards:

EN 60950

Safety of information technology equipment including electrical business equipment

EN 61010

Safety requirements for electrical equipment for measurement, control and laboratory use Part 1: General requirements

If you use electrical equipment in installations and under ambient conditions requiring higher safety standards, you must comply with the provisions as specified in the applicable regulations for installation in your country.

Copyright by Acculab.

All rights reserved. No part of this publication may be reprinted or translated in any form or by any means without the prior written permission of Acculab.

The status of the information, specifications and illustrations in this manual is indicated by the date given below.

Acculab reserves the right to make changes to the technology, features, specifications and design of the equipment without notice.

Status:

May 2007, Acculab

W1A000 - KT
Publication No.: WAT6002-e07051



www.BilanceOnLine.it

BIS S.r.l.

Via Trieste, 31
20080 Bubbiano MI – Italia
Tel.: +39 02 90834207
Fax: +39 02 90870542
e-mail: info@BilanceOnLine.it

P.IVA 03774900967