

SURVIVOR® CW-80 Over/Under Checkweigher



Measurement
Canada
Approved

(SEE CHART ON BACK OF PAGE FOR PART #'S)

The SURVIVOR CW-80 features a new generation Tough-Touch™ keypad, designed to withstand the most demanding industrial applications. International symbols and an extra-bright, rapid response display make the CW-80 instantly readable in almost any environment.

A true NEMA 4X/IP66 indicator enclosure is designed to seal out moisture and contaminants. The exclusive LifeGuard™ shock-absorbing base provides exceptional protection against overload and impact forces on 10" x 10" and 12" x 12" platforms. A stainless steel load cell resists corrosion for long life in washdown applications (6-60 lb capacities only).

Making operation possible virtually anywhere, the CW-80 offers 115 VAC or 230 VAC power configurations, and optional battery "backup power" with one of three available outputs. Battery backup power eliminates down time due to power failure, and supports limited portability. Optional RS-485 communication enables interfacing to a computer network, while the transaction memory buffer saves the last weighments for network retrieval and analysis.

Applications

- Food processing
- Industrial processing
- Kit assembly operations
- General filling operations
- General purpose weighing

Standard Features

- Large, bold 0.8" LED rapid-response display
- Industrial-quality 304 stainless steel construction
- Rugged 5-point overload protection on platform bases
- LifeGuard™ shock-absorbing bases on 6 lb to 100 lb capacities in base sizes up to 12" x 12"
- Highly-durable and corrosion-resistant stainless steel load cell on 6 lb to 60 lb capacities
- Field-proven aluminum load cell on 100 lb to 1000 lb capacities
- NEMA 4X/IP66 indicator enclosure
- ToughTouch™ industrial touch-control front panel with keys for over, under, tare, zero, units, print, target and ID
- Front-panel "Independent Key Disabling" for: OVER, UNDER, TARE, PRINT and UNITS keys
- Displays units in decimal lb, kg, oz, lb & oz, grams
- Annunciator lights for unit selection
- High-intensity LED for over, under and accept
- Storage for up to 300 tare and tolerance settings
- Automatic zero tracking
- 115 or 230 VAC operation
- Bidirectional RS-232 and/or simplex 20mA current loop communication

Options/Accessories

ELECTRONICS:

Option A 230 VAC operation

OUTPUTS:

Option B 3 TTL level setpoints

Option C ... 3 normally-open relays

Option D ... 3 normally-closed relays

Option E 3 TTL level setpoints with 6V battery backup power supply

Option F 3 normally-open relays with 6V battery backup power supply

Option G ... 3 normally-closed relays with 6V battery backup power supply

SOFTWARE:

Option H ... RS-485 communication

HARDWARE:

Option I* 12" column replacing standard column

Option J* ... 18" column replacing standard column

Option K* .. 24" column replacing standard column

Option L* ... 30" column replacing standard column

Option M ... Combination desk/wall mount bracket

Option N ... 10" x 10" cutting board, white food-grade plastic

Option O ... 12" x 12" cutting board, white food-grade plastic

Option P 304 stainless steel clamshell load cell protection, 12" x 12" model, 100 lb capacity only

41292 304 stainless steel clamshell load cell protection for capacities of 100 lb and over

* Please note if you are ordering the column without the scale refer to the Replacement Parts Catalog for necessary components and pricing.

Please consult factory for pricing if your application requires hermetically sealed load cells.

DISPLAY:

Large 0.8" 7-segment, 6-digit high-intensity red LED display, Decimal point available at each digit

STATUS ANNUNCIATORS:

lb, kg, g, net, motion, center of zero, neg

KEYBOARD:

8-key tough control with international symbols

BAR GRAPH:

5-segment, 7-range programmable multicolored array tracks
Over, Under, Accept status in relation to target value

INTERNAL RESOLUTION:

50,000 to 1,000,000 based on filtering selection

DISPLAY RESOLUTION:

Selectable up to 50,000 dd

MEASUREMENT RATE:

25 updates/second

SYSTEM LINEARITY:

0.01% of F.S.

ZERO STABILITY:

100 nV/°C maximum

SPAN STABILITY:

3ppm/°C maximum

AZM (ZERO TRACK):

off, ±.5, 1, 2 or 3 dd

OPERATIONAL AZM:

±2% or 100% F.S

MOTION BAND:

Off, .5, 1, 2, 3, 5, 10 dd

CALIBRATION METHOD:

Software

EXCITATION VOLTAGE:

10 ± .05 VDC, 4 x 350Ω load cell

DIGITAL FILTER:

Software selectable 1, 2, 4, 8, 16, 32, 64, 128

SENSE AMPLIFIER:

Differential amplifier with 6-wire sensing

RFI PROTECTION:

Signal, excitation and sense lines protection. 33V/m for 100 kHz to 1 GHz, ≤1 μV susceptibility

DIGITAL OUTPUTS:

(Optional) 3 TTL outputs (5VDC) or 3 N/O relays (10 watts, 0.5 amp, 100 VDC) or 3 N/C relays to (10 watts, 0.5 amp, 100 VDC)

EPD PORT:

Full duplex, RS-232 or 20 mA simplex output (RS-485 optional)

LINE VOLTAGES:

Available in 115 or 230 VAC (nom.) models

FREQUENCY:

50 or 60 Hz

OPERATING TEMPERATURE:

14°F to 104°F (-10°C to 40°C)

INDICATOR DIMENSIONS:

9.5" W x 8.5" H x 3.25" D (241mm x 216mm 83)

APPROVALS:

System approved to 3,000 divisions, NTEP-certified per H-44: Indicator, 10,000d, Class III/IIIL, CC #96-118A1, Base, CC #96-107. Measurement Canada approved: Indicator, AM-5146, Base, AM-5156, OIML certificate #R76/1992-DE-97.02, UL & C-UL listed, CE marked

WARRANTY:

Two year limited warranty

OVERALL DIMENSIONS (APPROX):

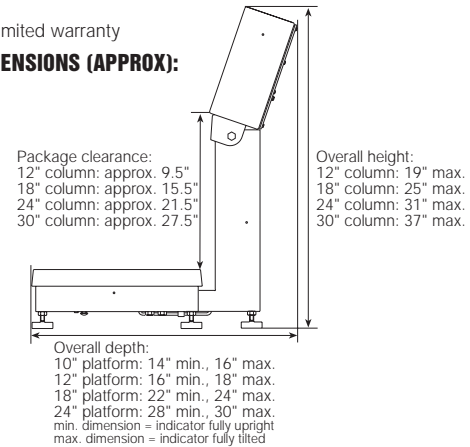

PART #	CAPACITY LB (KG)	PLATFORM DIMENSIONS INCHES (MM)	COLUMN HT. INCHES (MM)	SHIP WEIGHT LB (KG)
35113	6 lb x .002 (3 kg x .001) 96 oz x .05	10" L x 10" W x 3" H (254mm L x 254mm W x 77mm H)	12" (305mm)	20 lb (8.8 kg)
35114	10 lb x .005 (5 kg x .002) 160 oz x .1	10" L x 10" W x 3" H (254mm L x 254mm W x 77mm H)	12" (305mm)	20 lb (8.8 kg)
35115	15 lb x .005 (7 kg x .002) 240 oz x .1	10" L x 10" W x 3" H (254mm L x 254mm W x 77mm H)	12" (305mm)	20 lb (8.8 kg)
35116	30 lb x .01 (15 kg x .005) 480 oz x .2	10" L x 10" W x 3" H (254mm L x 254mm W x 77mm H)	12" (305mm)	20 lb (8.8 kg)
35121	30 lb x .01 (15 kg x .005) 480 oz x .2	12" L x 12" W x 3" H (305mm L x 305mm W x 77mm H)	12" (305mm)	23 lb (10.4 kg)
35122	60 lb x .02 (30 kg x .01) 960 oz x .5	12" L x 12" W x 3" H (305mm L x 305mm W x 77mm H)	12" (305mm)	23 lb (10.4 kg)
35175	100 lb x .02 (50 kg x .01) 1600 oz x .5	12" L x 12" W x 3" H (305mm L x 305mm W x 77mm H)	12" (305mm)	23 lb (10.4 kg)
35176	100 lb x .02 (50 kg x .01) 1600 oz x .5	18" L x 18" W x 5.25" H (457mm L x 457mm W x 134mm H)	18" (458mm)	78 lb (35.4 kg)
35177	200 lb x .05 (100 kg x .02) 3200 oz x 1	18" L x 18" W x 5.25" H (457mm L x 457mm W x 134mm H)	18" (458mm)	78 lb (35.4 kg)
35178	300 lb x .1 (150 kg x .05) 4800 oz x 2	18" L x 18" W x 5.25" H (457mm L x 457mm W x 134mm H)	18" (458mm)	78 lb (35.4 kg)
35179	500 lb x .1 (250 kg x .05) 8000 oz x 2	18" L x 18" W x 5.25" H (457mm L x 457mm W x 134mm H)	18" (458mm)	78 lb (35.4 kg)
35181	200 lb x .1 (100 kg x .05) 3200 oz x 2	24" L x 18" W x 5.25" H (610mm L x 457mm W x 134mm H)	18" (472mm)	95 lb (43.1 kg)
35182	300 lb x .1 (150 kg x .05) 4800 oz x 2	24" L x 18" W x 5.25" H (610mm L x 457mm W x 134mm H)	18" (472mm)	95 lb (43.1 kg)
35183	500 lb x .1 (250 kg x .05) 8000 oz x 5	24" L x 18" W x 5.25" H (610mm L x 457mm W x 134mm H)	18" (472mm)	95 lb (43.1 kg)
35184	1000 lb x .2 (500 kg x .1) 16000 oz x 5	24" L x 18" W x 5.25" H (610mm L x 457mm W x 134mm H)	18" (472mm)	95 lb (43.1 kg)
35185	200 lb x .05 (100 kg x .02) 3200 oz x 1	24" L x 24" W x 5.25" H (610mm L x 610mm W x 134mm H)	18" (472mm)	110 lb (49.9 kg)
35186	300 lb x .1 (150 kg x .05) 4800 oz x 2	24" L x 24" W x 5.25" H (610mm L x 610mm W x 134mm H)	18" (472mm)	110 lb (49.9 kg)
35187	500 lb x .1 (250 kg x .05) 8000 oz x 2	24" L x 24" W x 5.25" H (610mm L x 610mm W x 134mm H)	18" (472mm)	110 lb (49.9 kg)
35188	100 lb x .2 (50 kg x .1) 16000 oz x 5	24" L x 24" W x 5.25" H (610mm L x 610mm W x 134mm H)	18" (472mm)	110 lb (49.9 kg)
KG ONLY (230 VAC)				
66682	3 kg x .001	10" L x 10" W x 3" H (254mm L x 254mm W x 77mm H)	12" (305mm)	20 lb (8.8 kg)
66681	5 kg x .002	10" L x 10" W x 3" H (254mm L x 254mm W x 77mm H)	12" (305mm)	20 lb (8.8 kg)
66680	7.5 kg x .005	10" L x 10" W x 3" H (254mm L x 254mm W x 77mm H)	12" (305mm)	20 lb (8.8 kg)
68667	7.5 kg x .005	10" L x 10" W x 3" H (254mm L x 254mm W x 77mm H)	3" (76.2mm)	20 lb (8.8 kg)
OIML CERTIFIED (230 VAC)				
51200	30 lb x .01 (15 kg x .005) 480 oz x .2	10" L x 10" W x 3" H (254mm L x 254mm W x 77mm H)	12" (305mm)	20 lb (8.8 kg)
51201	30 lb x .01 (15 kg x .005) 480 oz x .2	12" L x 12" W x 3" H (305mm L x 305mm W x 77mm H)	12" (305mm)	23 lb (10.4 kg)
51202	60 lb x .02 (30 kg x .01) 960 oz x .5	12" L x 12" W x 3" H (305mm L x 305mm W x 77mm H)	12" (305mm)	23 lb (10.4 kg)