

FB 3000

SOLUTION SERIES INSTRUMENTS

• Remote Terminals • Solid Waste • Transfer Stations • Sand & Gravel • Mining • Agriculture

The Ultimate Instrument for Truck Scale Applications



INTALOGIX
TECHNOLOGY



The reliability of a Fairbanks Instrument, the convenience of a PC platform.
The FB 3000 is the most versatile scale instrument ever engineered!

Balances LEDUC & THIBEAULT Inc.

www.leduc-thibeault.com



**Catch the Wave in
FB 3000 Instruments**



FB 3000

Solution Series Instruments

What's so different about the FB 3000 Solution Series?

Everything. This new Fairbanks instrument was designed and engineered to revolutionize the acquisition and handling of Truck Scale data through its innovative Windows® XP software platform. Because it functions like a PC, it's easy to operate, just like a PC.

This instrument offers unsurpassed data storage capabilities and connectivity options, as well as an integrated email client that can be configured to instantly alert a scale operator to changes that could hamper weighing operation performance.

It's so versatile, it can interface with regular analog load cells, Fairbanks' renowned digital Intalogix® Technology system, and yes, even load cells produced by competing manufacturers.

The power Fairbanks has given to the FB 3000 Instrument WILL streamline your operation's automation capabilities, providing instant data in any programmable language to those who need the information most: plant managers, maintenance supervisors and accounting and IT personnel. It can even connect to a company network and interface with your existing laser printers and PCs, as well as a long list of other peripheral devices.

The FB 3000 is available in three enclosure types to meet the needs of any application environment and comes with an impressive 10.4" SVGA color display, mini keyboard and mouse.

The FB 3000 is yet another example of how Fairbanks Scales brings the cutting-edge in weighing technology to the world. Don't miss this opportunity to take your weighing operation to a higher performance level.

Industry's Most Advanced Standard Features

- 128 MB internal memory
- 40 GB disk drive
- 85-key mini keyboard
- 2-button scroll mouse
- 10.4" full color, high resolution display
- 802.11 connectivity compatible
- Embedded Windows XP software
- Ports: Ethernet, 4 Serial, 2 internal USB, 2 external USB, 1 PS2, 1 RS232/ 4851422, and 1 parallel

Options • Touch screen • Flash card for backup storage • Analog or Intalogix® Technology

Functions

- In/Out weighing
- Tare storage
- GTN weighing
- Onboard backup
- Formattable tickets
- Drives up to four scales simultaneously (up to 40 cells with Intalogix Technology)
- Load cell diagnostics with Intalogix option

Virtual Tour Take an FB 3000 Virtual Tour at www.fairbanks.com/FB3000.

Remote Terminal with Card Reader? No problem! Done in 5 easy steps.

1. Scale user drives onto scale and swipes card or enters ID number.
2. User chooses "Bill to Account."
3. User selects type of "Material" being weighed.
4. User confirms weighment information or selects "Start Over" to edit.
5. Weight is taken, recorded to database, and ticket printed.



Remote configuration capabilities? Fairbanks is breaking new ground, again.

The FB 3000 has a factory loaded utility that allows remote configuration from anywhere in the world, provided there is an Ethernet connection to the instrument. Fairbanks was the first to introduce such a tool back in the '90s with Winlogix® software. Now, Fairbanks has raised the bar again, taking remote access to new heights through the FB 3000's easy-to-use, interactive interface.

FB 3000

Solution Series Instruments

AN ADVANCED SOLUTION TO SIMPLIFY TRUCK SCALE DATA ACQUISITION

InterAct Software:

A package to fit any user need

Fairbanks' new InterAct Database Scale Transaction Software is the most complete truck scale data handling program ever written. It is designed for customers who need flexibility, data storage, data reporting and data networking capabilities.

InterAct is Windows XP compatible and runs on the new Fairbanks FB 3000 Instrument and most PCs. Three versions of InterAct are available; one is sure to fit your needs.

InterAct Inside - Standard on all FB 3000 models
Feature-packed software for in/out weighing, stored tares, basic material tracking and basic reporting.

InterAct Standard - Factory option or field upgrade
Offers custom reports, table pricing, freight charges, trailer tares and an import/export utility.

InterAct Professional - Factory option or field upgrade
Offers accounting features such as invoicing, payment tracking and reconciliation reports.

Call your local Fairbanks representative today to schedule a hands-on FB 3000 demonstration!

Phenomenal Features



Stainless Steel enclosure for harsh, wash-down applications.



Black enamel finish for non-hostile environments.



Optional Slim Profile monitor for limitless mounting possibilities.



Optional Touch Screen.

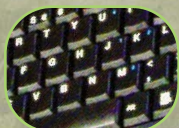

85-key mini keyboard and two-button scroll mouse come as standard features with all FB 3000 models.



Adjustable ergonomic knobs lock screen into a comfortable angle, reducing worker fatigue.

Many ports and connection possibilities



NTEP
Approved for commercial applications.

FB 3000

SOLUTION SERIES
INSTRUMENTS

DIMENSIONS

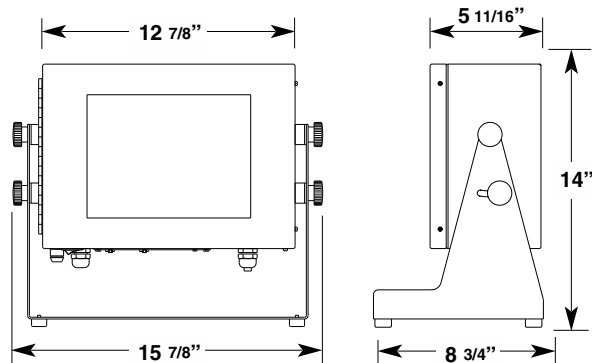

ACCESSORIES

- Touch Screen
- Flash Card
- Expansion Serial Ports
- Expansion USB Ports

SPECIFICATIONS

Display	10.4" Color SVGA - 600 x 800
Memory	128 MB RAM (expandable)
Storage	40 GB (expandable)
SDD Interface	One 50-pin compact Flash socket; flash card is optional
Enclosure	SS NEMA 12; Painted steel NEMA 12
Device Platform	XP embedded
Outputs	4 USB ports - Two external (expandable); 4 Serial ports (expandable) - Three RS-232 and one S 232/422/485 1 RJ45 port for network connection, PCI 100/10 Mbps Ethernet controller; 1 Parallel port, one bi-directional parallel port supports SPP/ECP/EPP; 1 SVGA port (internal); 1 PS2 port, supports PC/AT keyboard PS2 mouse
HID	Mini keyboard (black), 87 key, PS2
Mouse	2 button, black, USB
Number of scales	Up to 4 with Intalogix Card installed; 1 with Analog Card installed (expandable)
Battery	Lithium, data retention up to 10 years
Options	Expanded Memory; Analog or Intalogix®; Touch Screen - includes electronics, hardware and factory installation, load cell interface
Approvals	NTEP COC# 04-013A1

Leasing

Convenient, affordable leasing options available through Fairlease. Ask your Fairbanks sales representative for details.

Call toll-free for the representative nearest you:

Balances LEDUC & THIBEAULT Inc.

Montréal : (514) 239-7060 Mercier : (450) 691-2111

Sans-frais : 1-877-691-2111

www.leduc-thibeault.com email : info@leduc-thibeault.com



St. Johnsbury manufacturing
facility registered in
compliance with ISO 9001:2000.

