

FAIRBANKS®

FB 3000 SOLUTION SERIES INSTRUMENTS FOR TRUCK SCALES



The new FB 3000 Solution Series Instrument has more connectivity options and data acquisition capabilities than any other scale instrument on the planet. With combined features of both an instrument and PC, the FB 3000 allows truck scale clients to program the unit in any computer language or with their own specialized software. It can even connect directly to a company network.

STANDARD FEATURES

- 128 MB internal memory and 40 GB disk drive
- 85-key mini keyboard and 2-button scroll mouse
- 10.4" full color, high resolution graphics, display screen
- 802.11 standard connectivity compatible
- Embedded Windows® XP software
- Ethernet, 4 Serial ports, 2 internal USB ports, 2 external USB ports, 1 RS232/485/1422 port, 1 parallel port and 1 PS2 port

OPTIONS

- Touch screen
- Flash card for backup storage
- Analog or Intalogix® Technology

FUNCTIONS

- GTN weighing — In/Out weighing —Stores Tares —Formattable tickets
- Onboard backup routine
- Drives up to four scales simultaneously - up to 40 load cells with Intalogix
- Load cell diagnostics with Intalogix option

Display	10.4" Color SVGA - 600 x 800
Memory	128 MB RAM (expandable)
Storage	40 GB (expandable)
SDD Interface	One 50-pin compact Flash socket; flash card is optional
Enclosure	SS NEMA 12; Painted steel NEMA 12
Device Platform	XP embedded
Outputs	4 USB ports - Two external (expandable); 4 Serial ports (expandable) - Three RS-232 and one S 232/422/485 1 RJ45 port for network connection, PCI 100/10 Mbps Ethernet controller; 1 Parallel port, one bi-directional parallel port supports SPP/ECP/EPP; 1 SVGA port (internal); 1 PS2 port, supports PC/AT keyboard PS2 mouse
HID	Mini keyboard (black), 87 key, PS2
Mouse	2 button, black, USB
Number of scales	Up to 4 with Intalogix Card installed; 1 with Analog Card installed (expandable)
Battery	Lithium, data retention up to 10 years
Options	Expanded Memory; Analog or Intalogix®; Touch Screen - includes electronics, hardware and factory installation, load cell interface
Approvals	NTEP COC# 04-013A1

DIMENSIONS

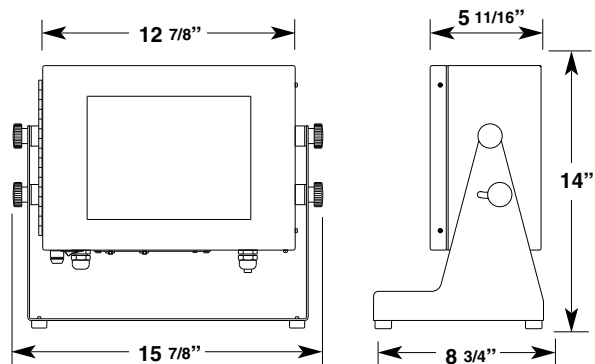

Leasing

Convenient, affordable leasing options available through Fairlease. Ask your Fairbanks sales representative for details.

QuickFacts™

Models and specifications subject to change without notice.
Printed in the USA on recycled paper. © Fairbanks Scales Inc.

Call toll-free for the Fairbanks representative nearest you:
Les Balances Leduc & Thibeault Scales Inc.

Montréal : (514) 239-7060 Mercier : (450) 691-2111