

FAIRBANKS®

2844 DIRECT THERMAL LABEL PRINTER



The 2844 Direct Thermal Label Printer delivers optimal performance for today's on-demand desktop labeling applications.

FLEXIBLE PRINTING

The 2844 features a new-generation printhead and enhanced controller board, motor and power supply, enabling print speeds of up to four inches per second. An OpenACCESS™ design and a clear media window make media loading and monitoring easy. A full five-inch media roll means fewer label changes. The 2844 is compatible with Windows® printer utilities and Windows® drivers (95, 98, Me NT v. 4.0, 2000). Parallel, serial and USB interfaces make this flexible, reliable and affordable printer a smart investment.

GREAT IN A VARIETY OF APPLICATIONS

The 2844 Thermal Label Printer integrates easily into a variety of low-volume printing applications including:

- Shipping/Receiving
- Warehouse shelf labeling and inventory control
- Hospitals and healthcare; medical laboratories
- Retail product marking
- Transportation/Logistics
- E-commerce postage

SPECIFICATIONS

Humidity	10% to 90% non-condensing
Power Requirements	110/240 VAC, 50/60 Hz
Enclosure	ABS double-walled casing
Physical Dimensions	Width: 7.9"; Depth: 8.38"; Height 6.7"; Weight: 3 lbs.
Print Speed	4" per second (selectable)
Print Resolution	203 dots per inch
Print Width	4.09" to 22"
Print Length	In page mode: 11" In line mode: Unlimited
Label & Liner Width	1" to 4.25"
Label Characteristics	Max. Roll Size: 5" O.D. on a 1" or 1.5" I.D. core Thickness (label & liner): .003 to .0075
Label Style	Gap, notch, black mark, continuous fanfold, tag stock
Label Type	Direct thermal
Bar Code Specifications	Linear Bar Codes; Code 39, Code 128 (A, B or C user selectable/Auto select), UCC/EAN-128, Code 93, Codabar, Interleaved 2 of 5
Approval	Listed by Underwriter Laboratory as complying with UL safety require- ments for Scales & Accessories.

DIMENSIONS

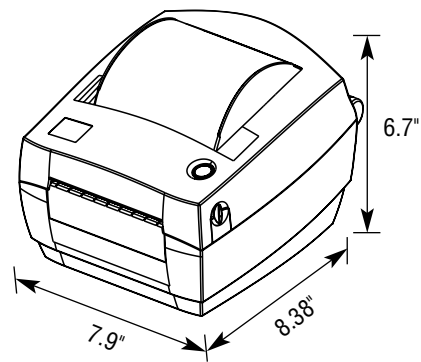

QuickFacts™

Models and specifications subject to change without notice.
Printed in the USA on recycled paper. © Fairbanks Scales Inc.

Call toll-free for the Fairbanks representative nearest you:

(800) 451-4107

Internet Address: <http://www.Fairbanks.com>